

# The Diffusion of Norms in the International System

Jonathan Ring  
University of Iowa

Prepared for EITM Workshop, June 17-28, University of Houston



# Research Question

How do different diffusion mechanisms affect the likelihood of norm internalization?

How can we distinguish between true believers and instrumental actors if their behavior is the same? Under what conditions will instrumental actors become true believers?

# The fundamental problem of observation

Internal state

Expression

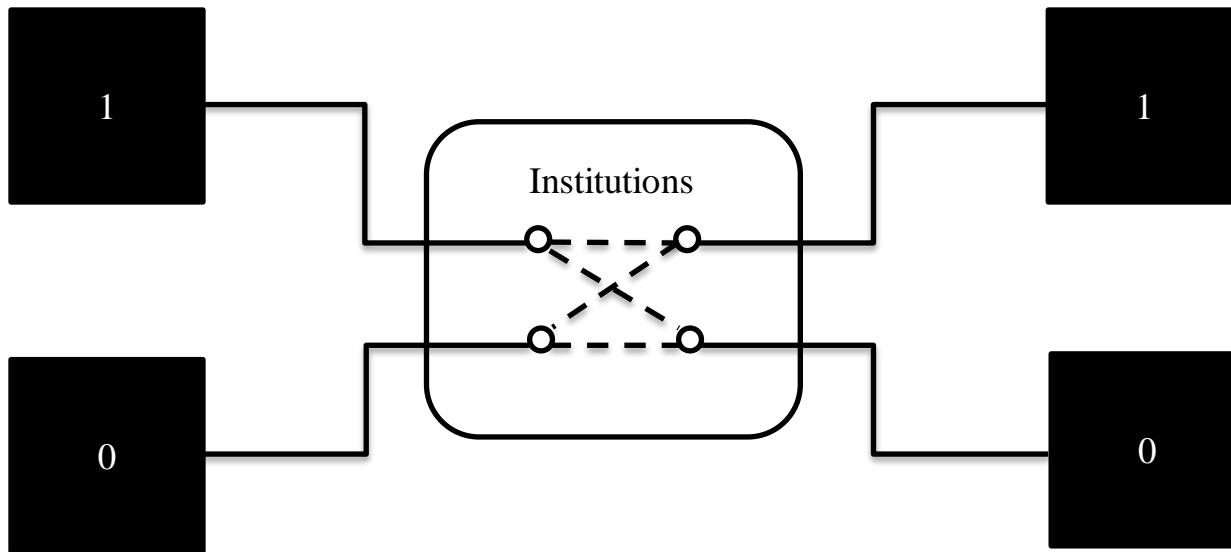

# Outline – The EITM Framework

1. Unifying theoretical and statistical concepts.
  - Theoretical concept: social interaction
  - Statistical concept: spatial and temporal interdependence in discrete choice
2. Develop formal and statistical analogues
  - Formal analogue: adaptation and homophily
  - Statistical analogue: dyadic event history
3. Unify and evaluate the analogues

# Literature: Norms

## Norm lifecycle:

Emergence → Acceptance → Internalization



Tipping Point/Norm Cascade

Norm: “collective expectations for the proper behavior of actors with a given identity” – Katzenstein 1996

An international norm begins with an idea innovated by individuals and ends as a widely institutionalized principle with the power to shape the identity/preferences of states.

## Diffusion S – Curves

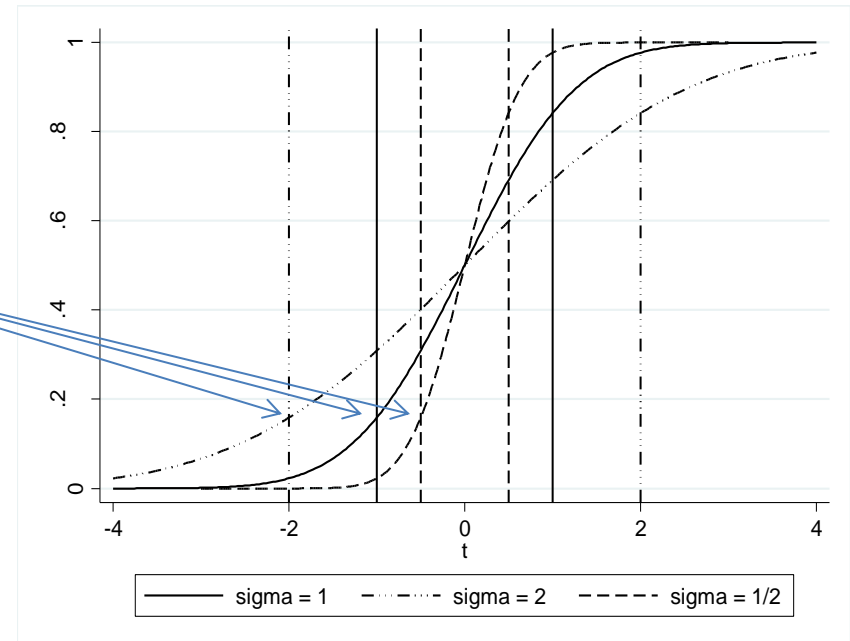

# Literature: Policy/Innovation Diffusion

Diffusion: diffusion is “any process where prior adoption of a trait or practice in a population alters the probability of adoption for remaining non-adopters” (Strang 1991, 325).

4 Diffusion Mechanisms:

Coercion, Competition, Emulation, and Learning

# Example: High School Fad

- “Do it or else”
- “Do it before it is uncool”
- “Do it because the cool kids do it”
- “Do it because those who have (haven’t) done it are better (worse) off”



# Theory: Distilling the Concepts

Convergence – a change in the form or behavior of one actor such that it becomes more like another actor.

is a function of:

Dependency – power and position in social hierarchy

Community – network and neighborhood

Identity – internal values and profile of attributes



# Theoretical Analogue

- Complex Adaptive System
  - The Generativist's experiment: Situate an initial population of autonomous heterogeneous agents in a relevant spatial environment; allow them to interact according to simple local rules, and thereby generate or “grow” a macroscopic regularity from the bottom up. (Epstein 2011)
- Start with Axelrod's model
  - 2 premises about culture:
    - More likely to interact with similar units
    - More interactions increases likeness between two units
  - Culture: a list of features (i.e. language) with various traits (German, French)

# Axelrod's (1997) Model of Cultural Dissemination

Fundamental modeling idea: Represent the process through which a unit adopts a cultural attribute.

Select a random site( $s$ ), a random neighbor of that site( $n$ ), and a random feature( $f$ ). Let  $G(s, n)$  be the set of features,  $g$ , such that the cultural traits are unequal, i.e.  $c(s, g) \neq c(n, g)$ . If  $c(s, f) = c(n, f)$  and  $G$  is not empty, then select a random feature,  $g$ , in  $G(s, n)$  and set  $c(s, g)$  to  $c(n, g)$ .

# Typical run of CD

Features = 5, traits = 10

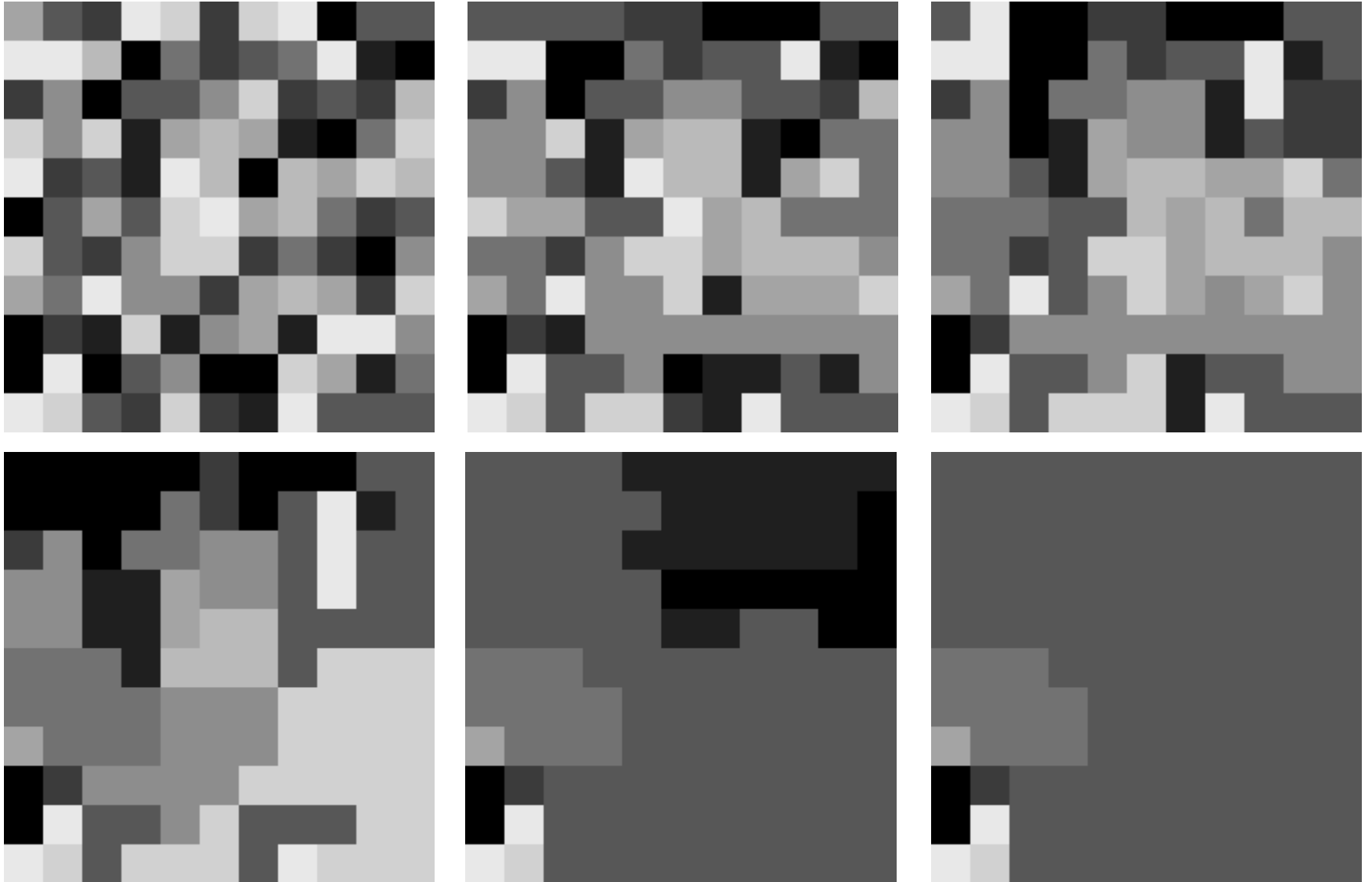

# Findings

- Key outcome: # of stable regions
  - Stable regions: each region has no possibility of interacting with adjacent region
  - Global divergence even under rules of local convergence
- Parameters:
  - # of features
    - More features leads to fewer stable regions
  - # of traits per feature
    - More traits leads to more stable regions
  - Definition of neighbor
    - Larger neighborhoods result in fewer stable regions
  - Size of the Territory
    - Inverted U

# My extension

- To capture the diffusion mechanisms,
  - Limit the # of features to 3 (power, identity-internal, identity-expression)
  - For power, create scale (0,1)
  - Change the likelihood of convergence such that,
    - *if*  $p_i > p_j$ ,  $\Pr(\text{convergence}) = 0$
    - *if*  $p_i < p_j$ ,  $\Pr(\text{convergence}) = p_j - p_i$

# Hypothesis

- From the agent-based framework: “Traits with more than one means of transmission have a greater tendency to homogeneity within populations, and also that horizontally transmitted traits are more likely to be spatially clustered.” – Gatherer (2002)

# Empirical Application: Gender Quotas

Gender Quotas: Innovations adopted by organizations which are designed to increase women's presence.

“Throughout the world women's organisations and political parties are searching for methods to end male dominance in politics. In principle, most people and governments support the idea of gender balance in political life. Today, introducing quota provisions in politics is considered a legitimate equal opportunity measure in many countries all over the world.”

- Dahlerup 2003, “Quotas are changing the history of women”

# 3 arguments for quota adoption

- From within
  - Domestic attributes of societies (opportunity structures) and strength of social movement actors (resource mobilization)
- From above
  - Coercion from powerful states, isomorphism to hegemonic culture
- From below
  - Networks of autonomous actors sharing ideas about justice, competition amongst states in the periphery to improve rank



# Diffusion of Quotas 1975-2007

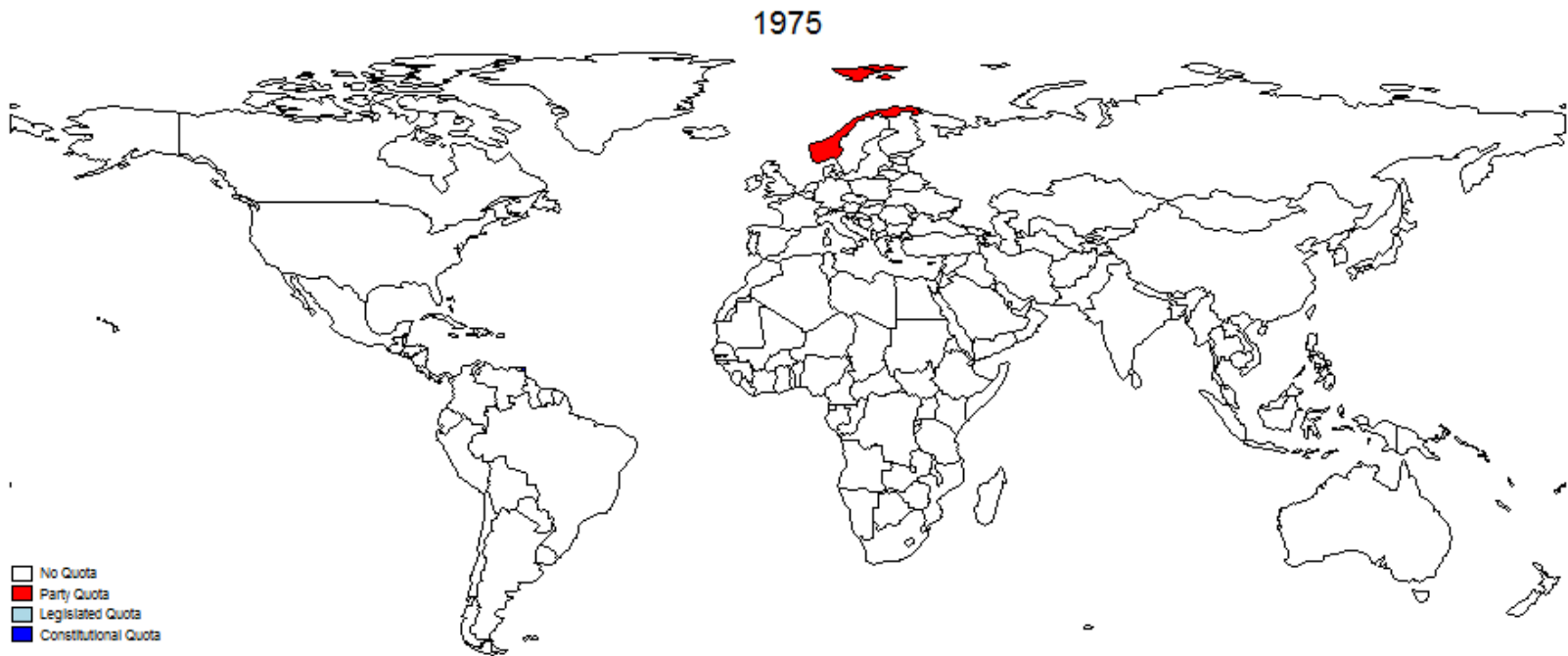

# Diffusion of Quotas 1975-2007

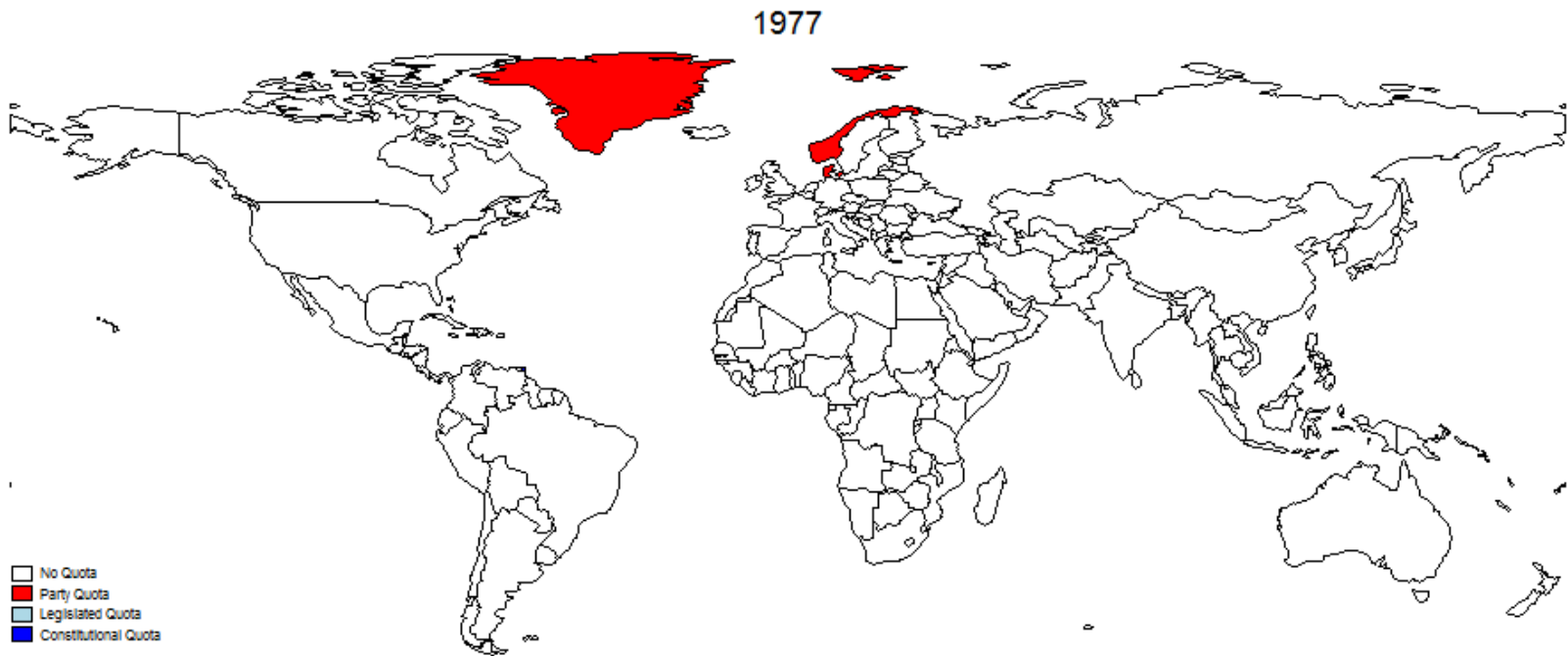

# Diffusion of Quotas 1975-2007

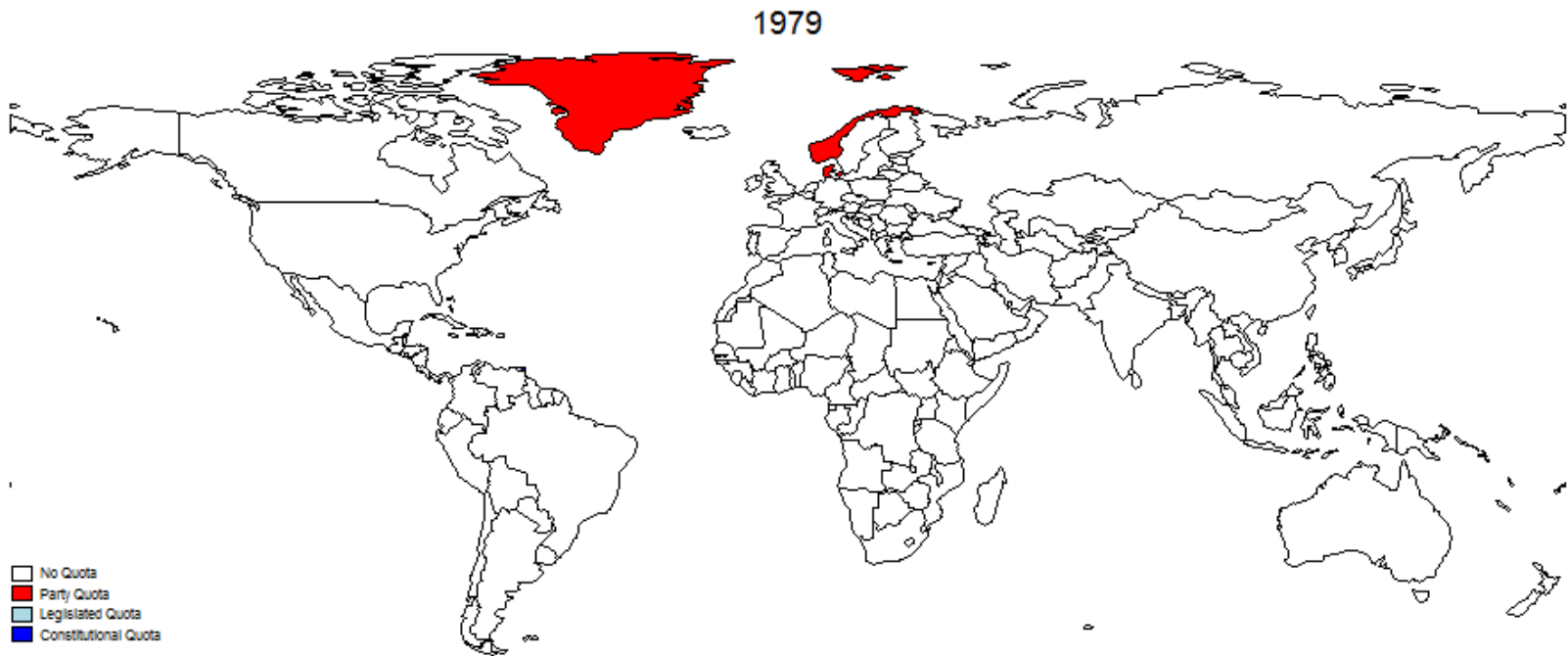

# Diffusion of Quotas 1975-2007

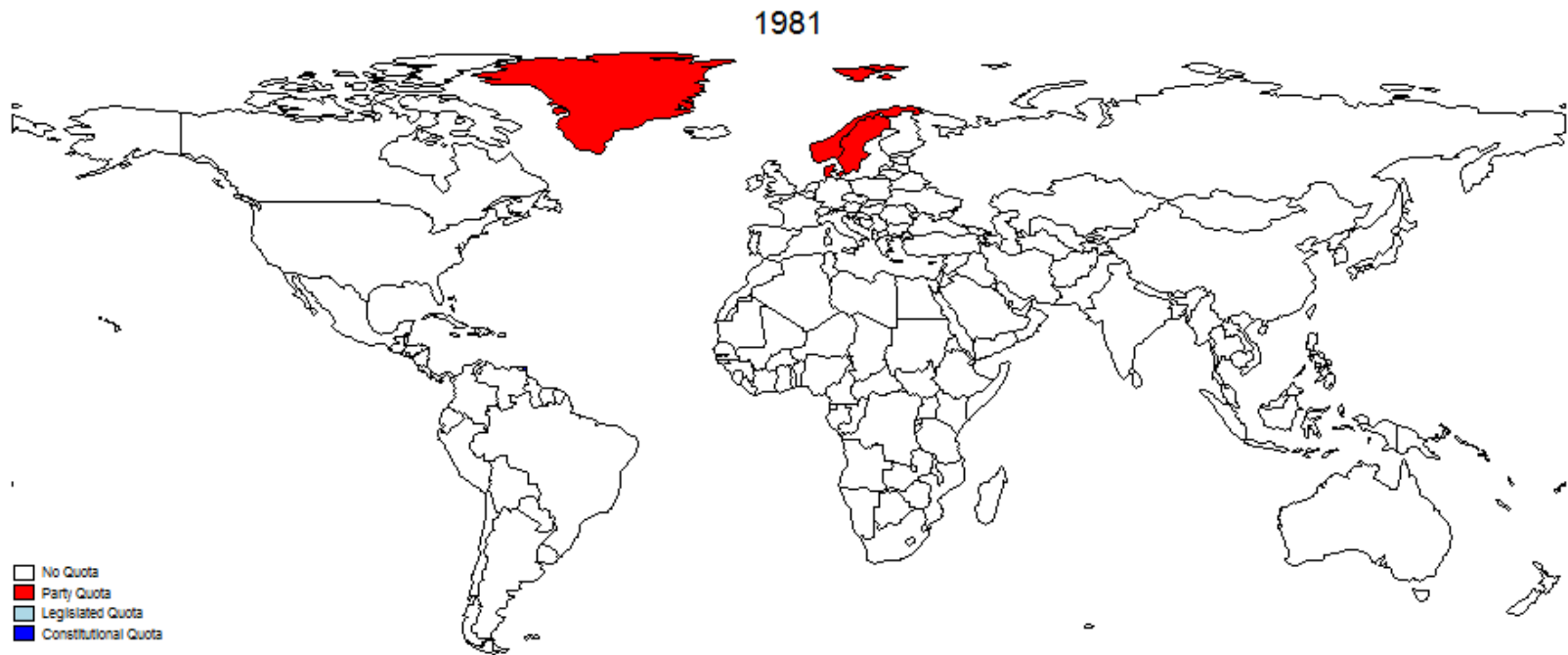

# Diffusion of Quotas 1975-2007

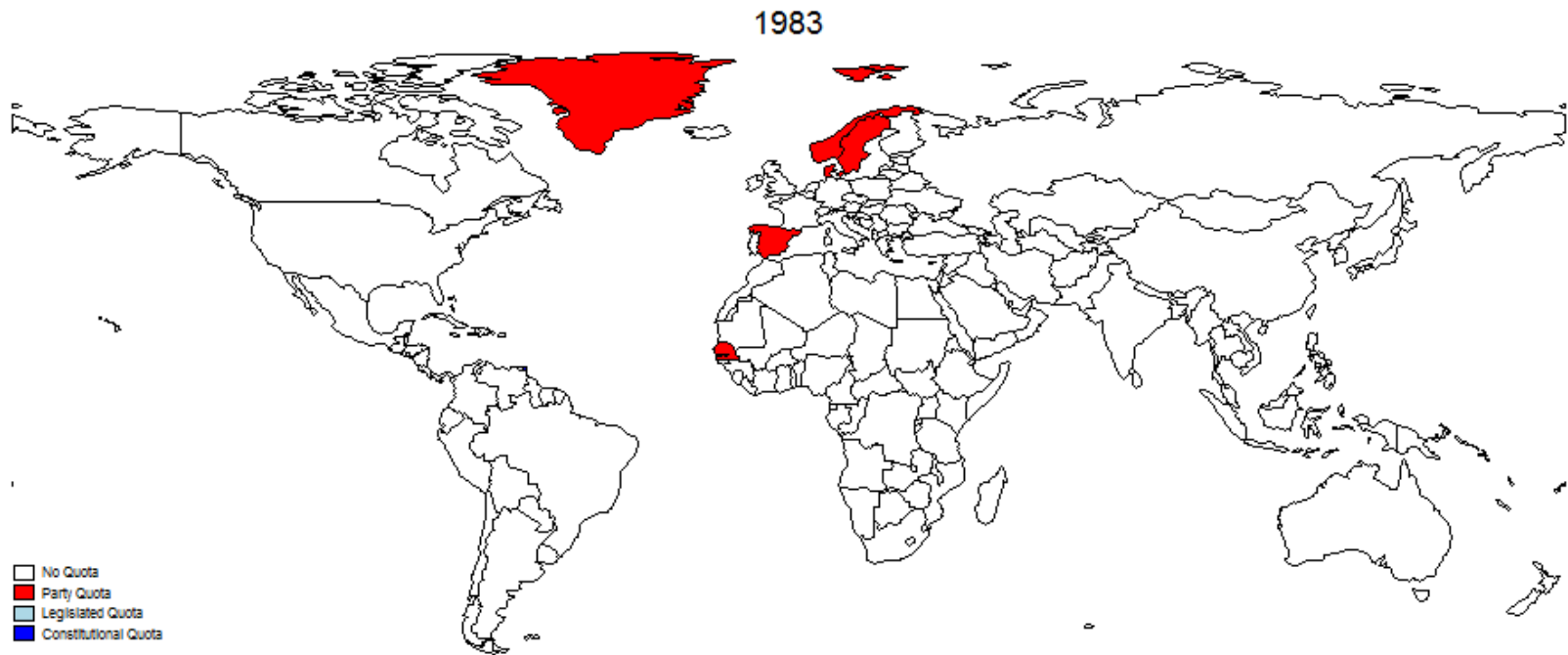

# Diffusion of Quotas 1975-2007

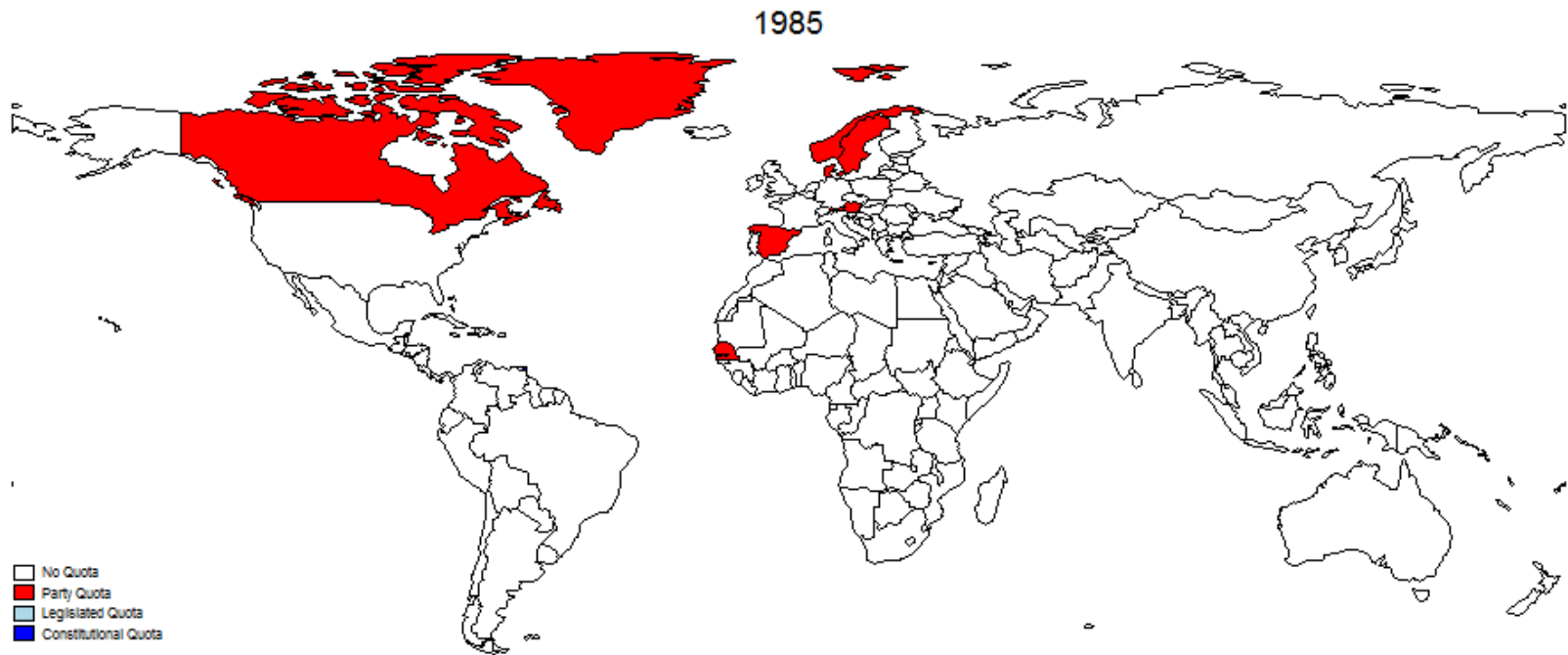

# Diffusion of Quotas 1975-2007

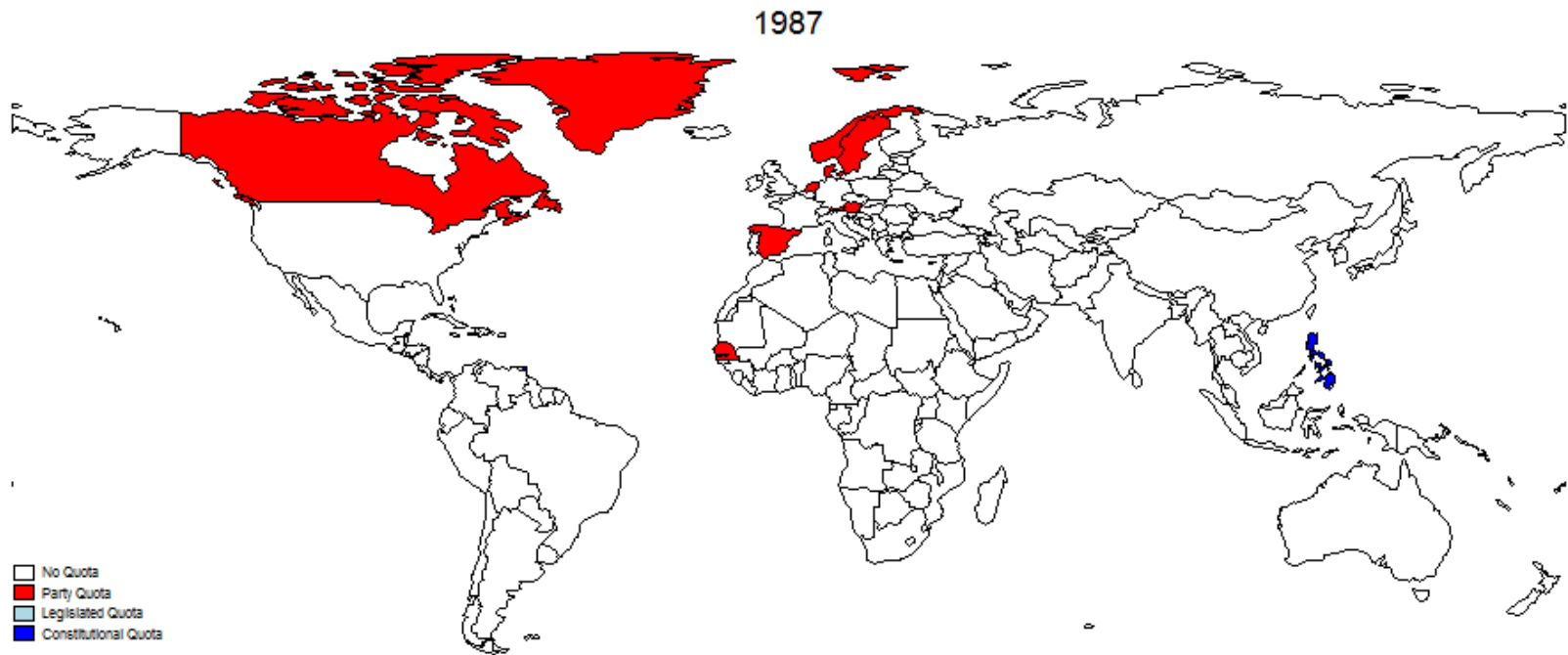

# Diffusion of Quotas 1975-2007

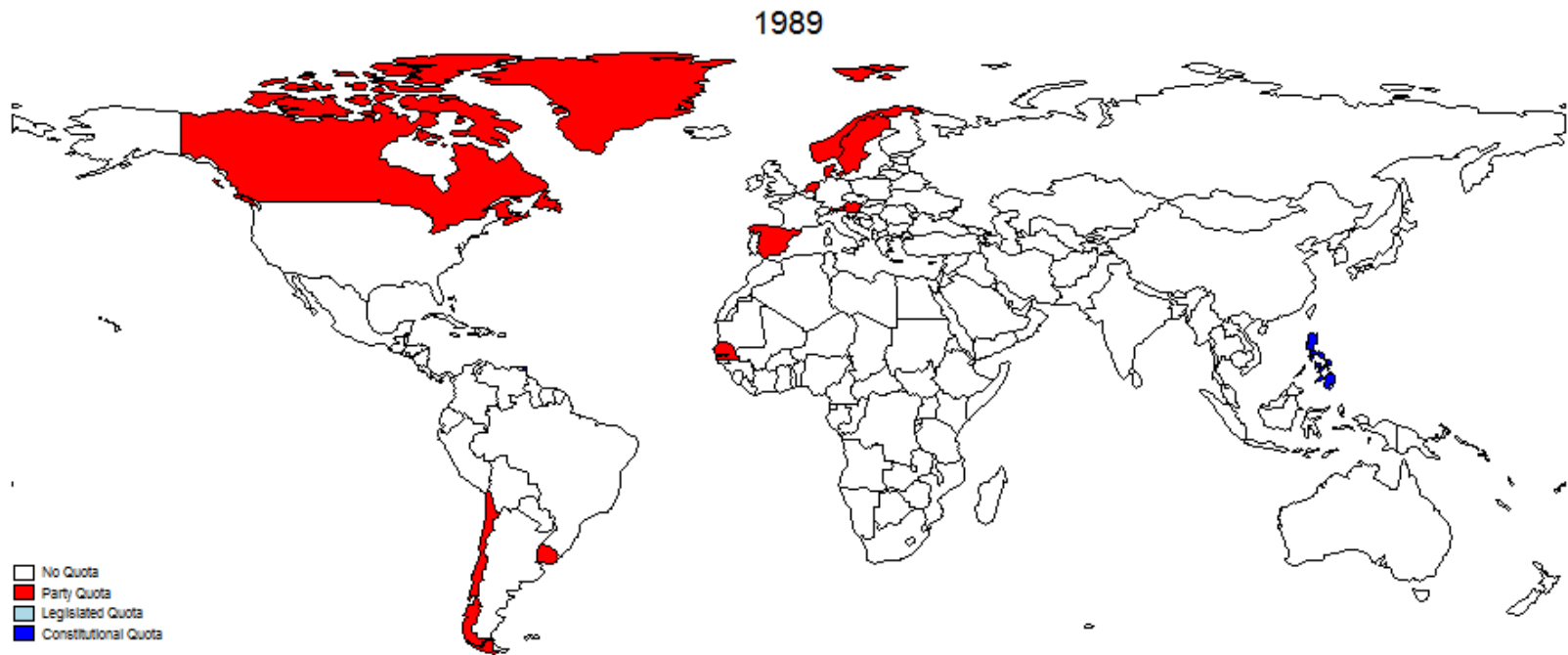



# Diffusion of Quotas 1975-2007

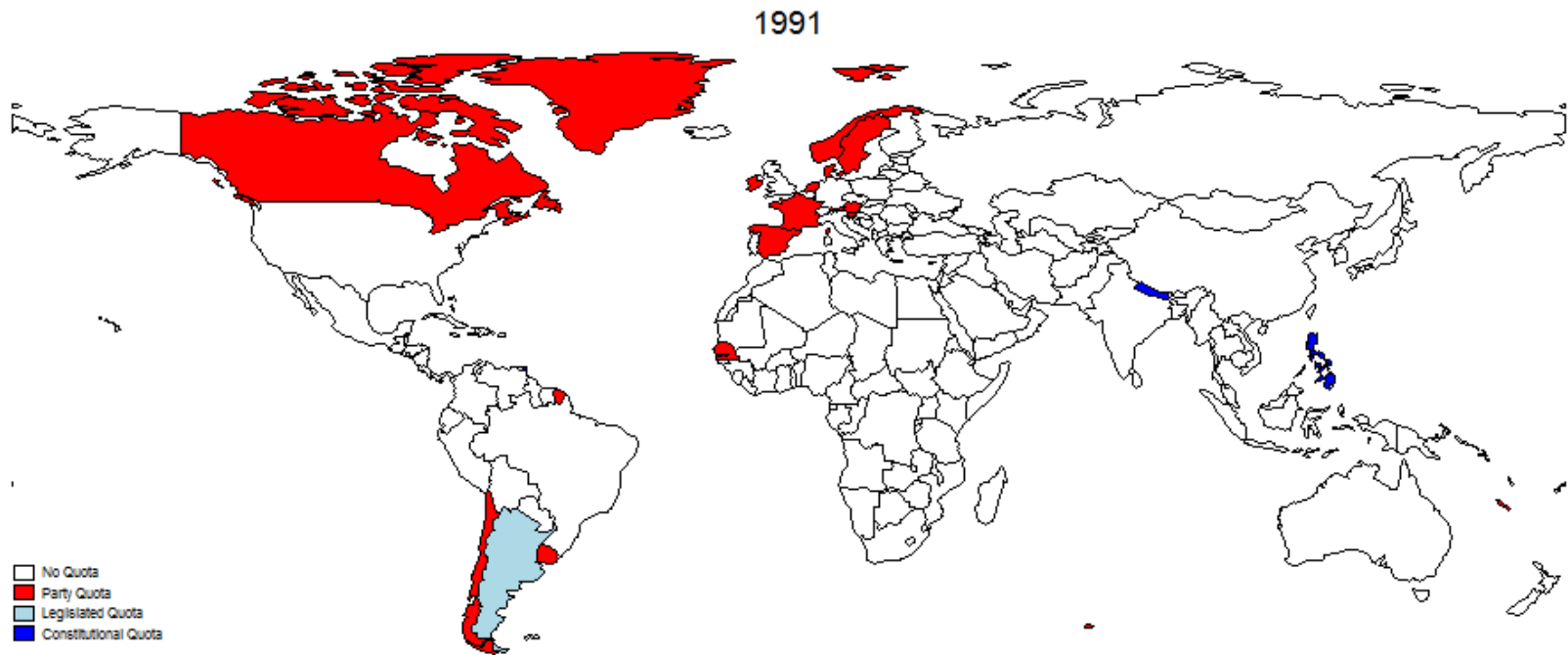

# Diffusion of Quotas 1975-2007

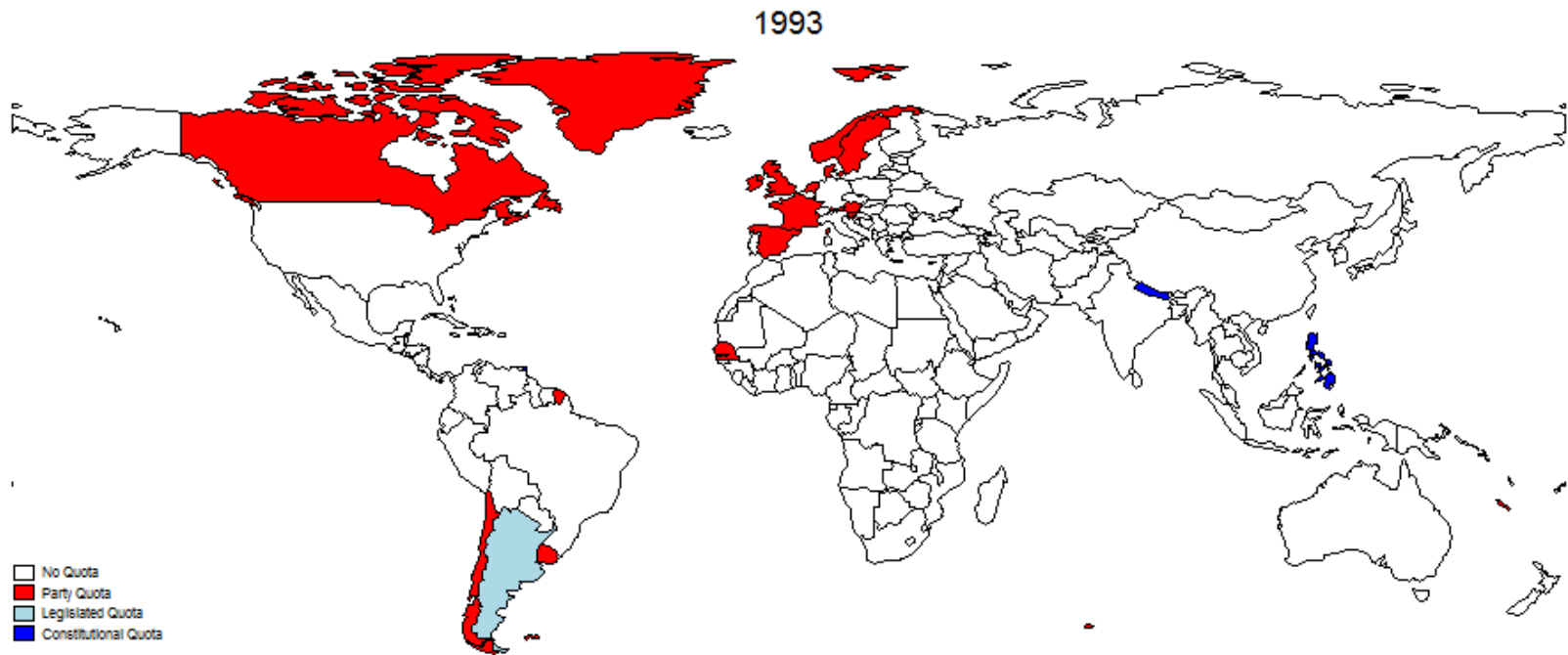

# Diffusion of Quotas 1975-2007

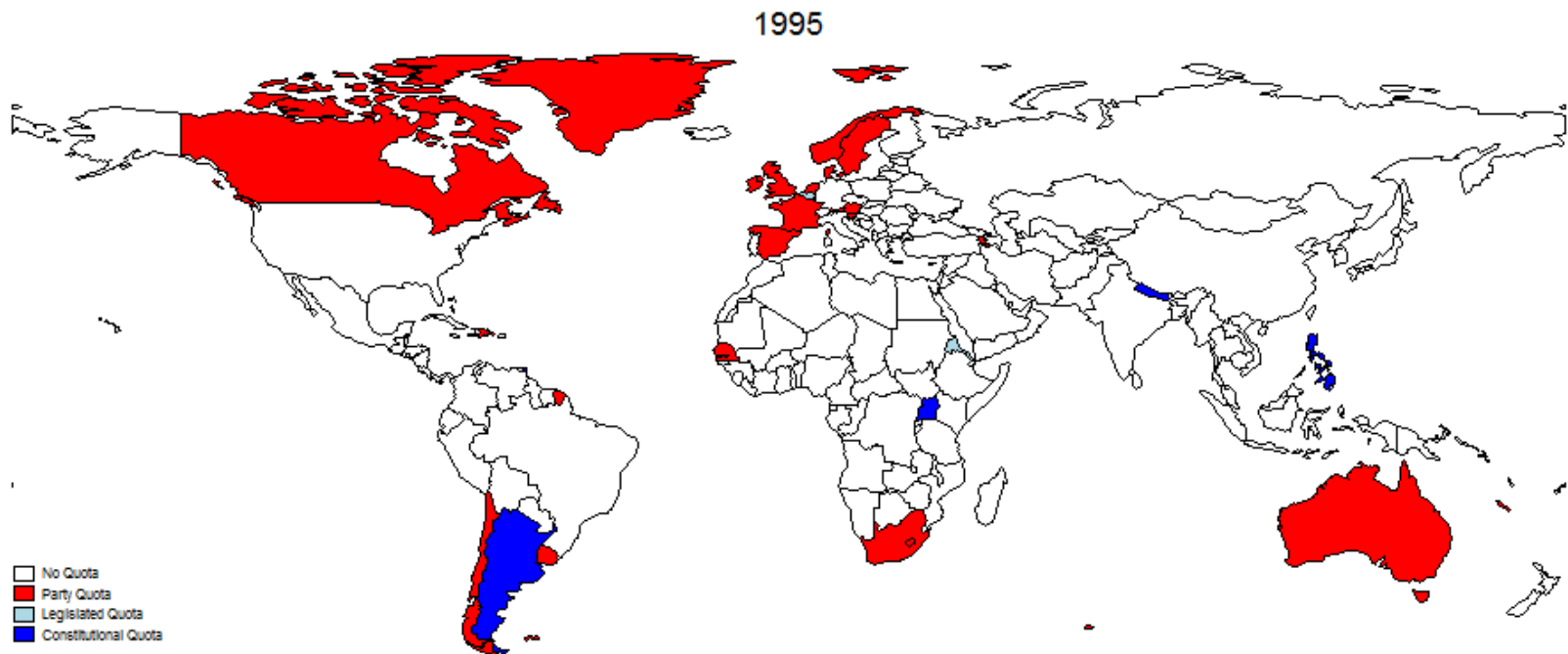

# Diffusion of Quotas 1975-2007

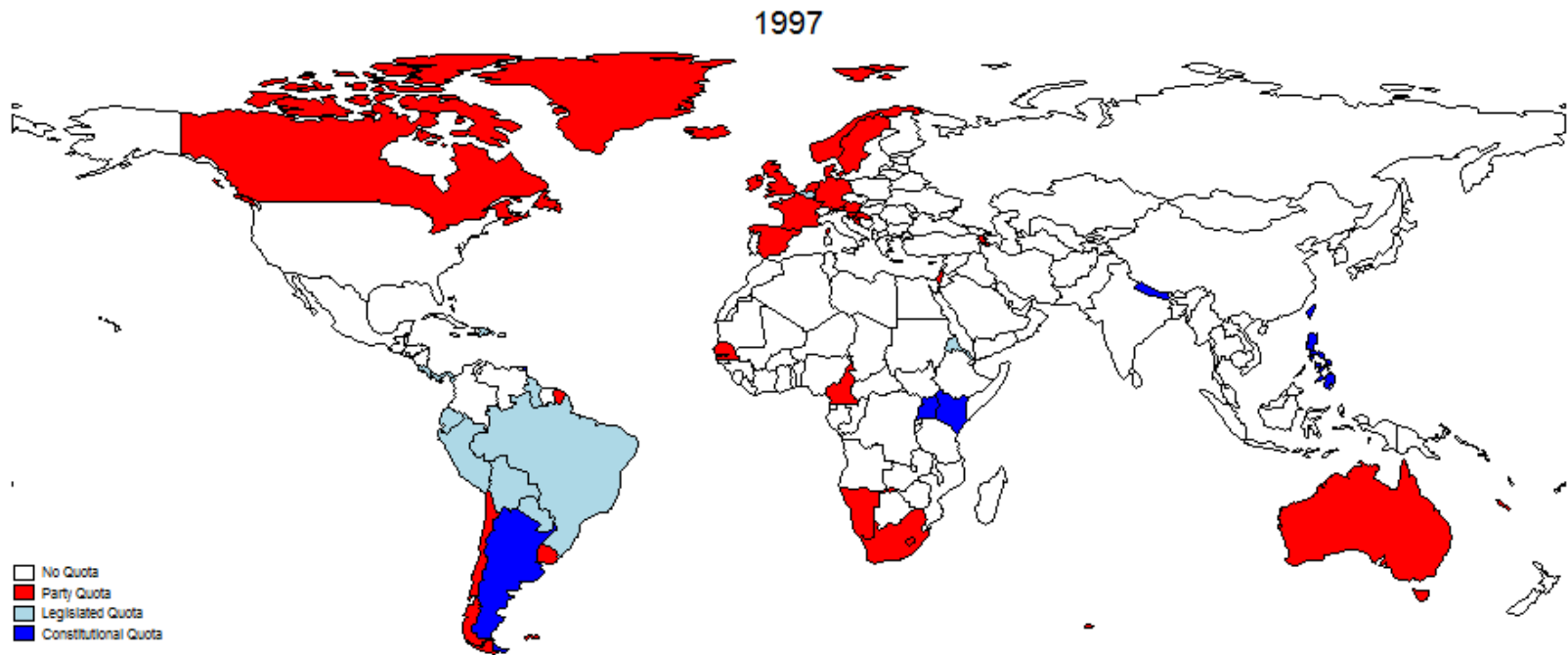

# Diffusion of Quotas 1975-2007

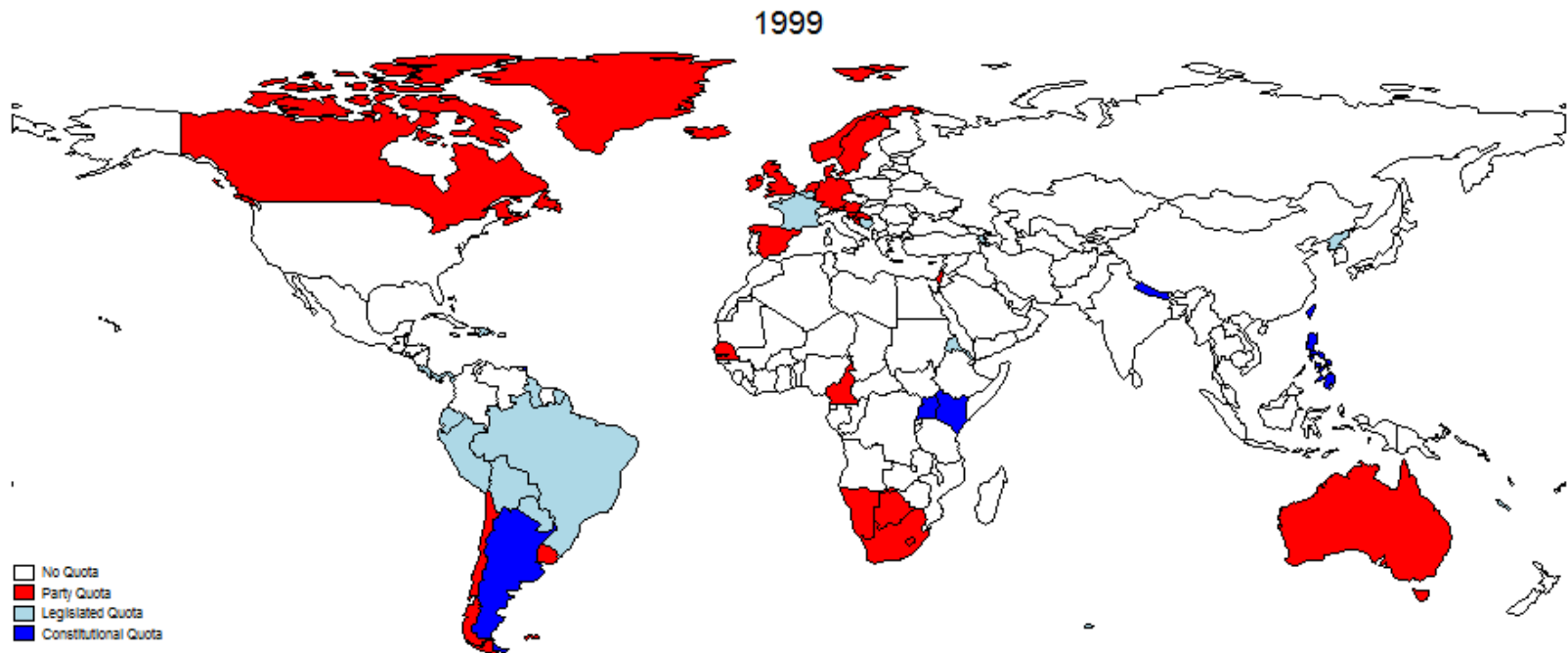

# Diffusion of Quotas 1975-2007

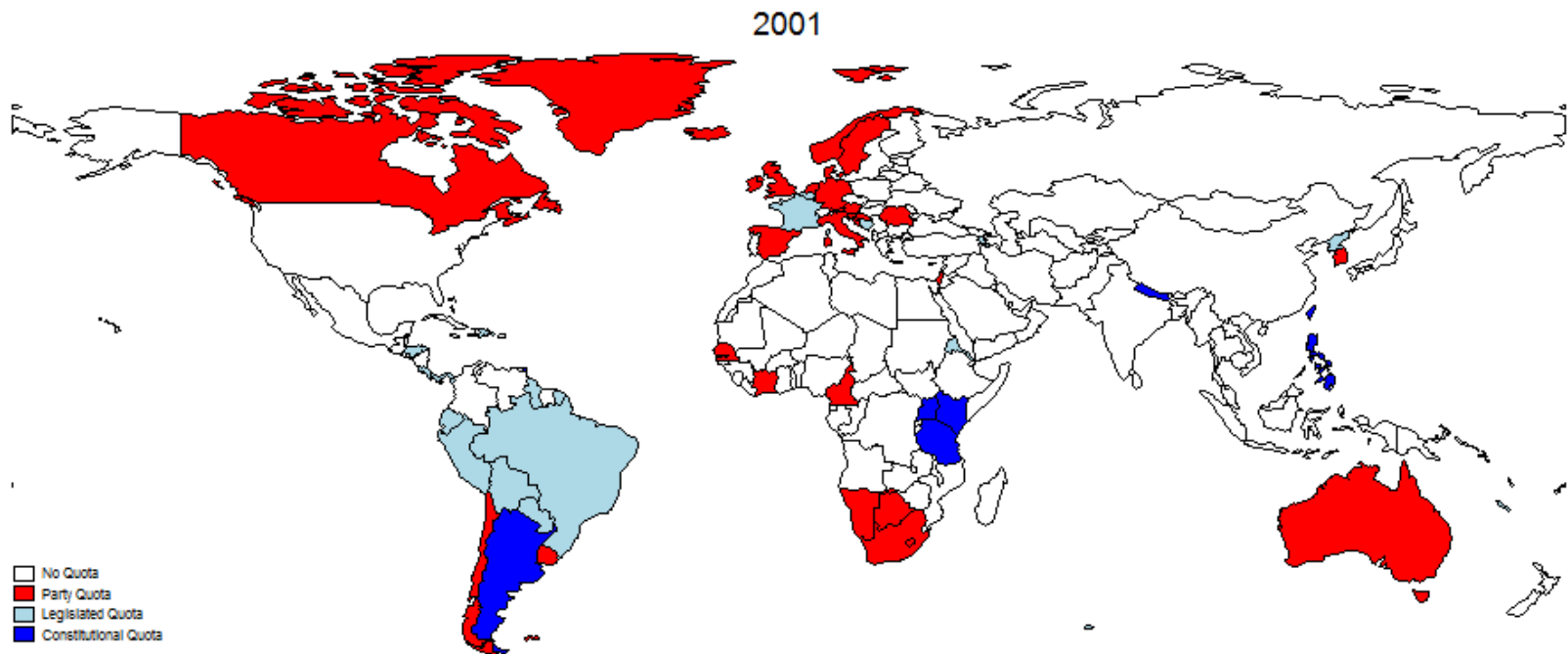

# Diffusion of Quotas 1975-2007

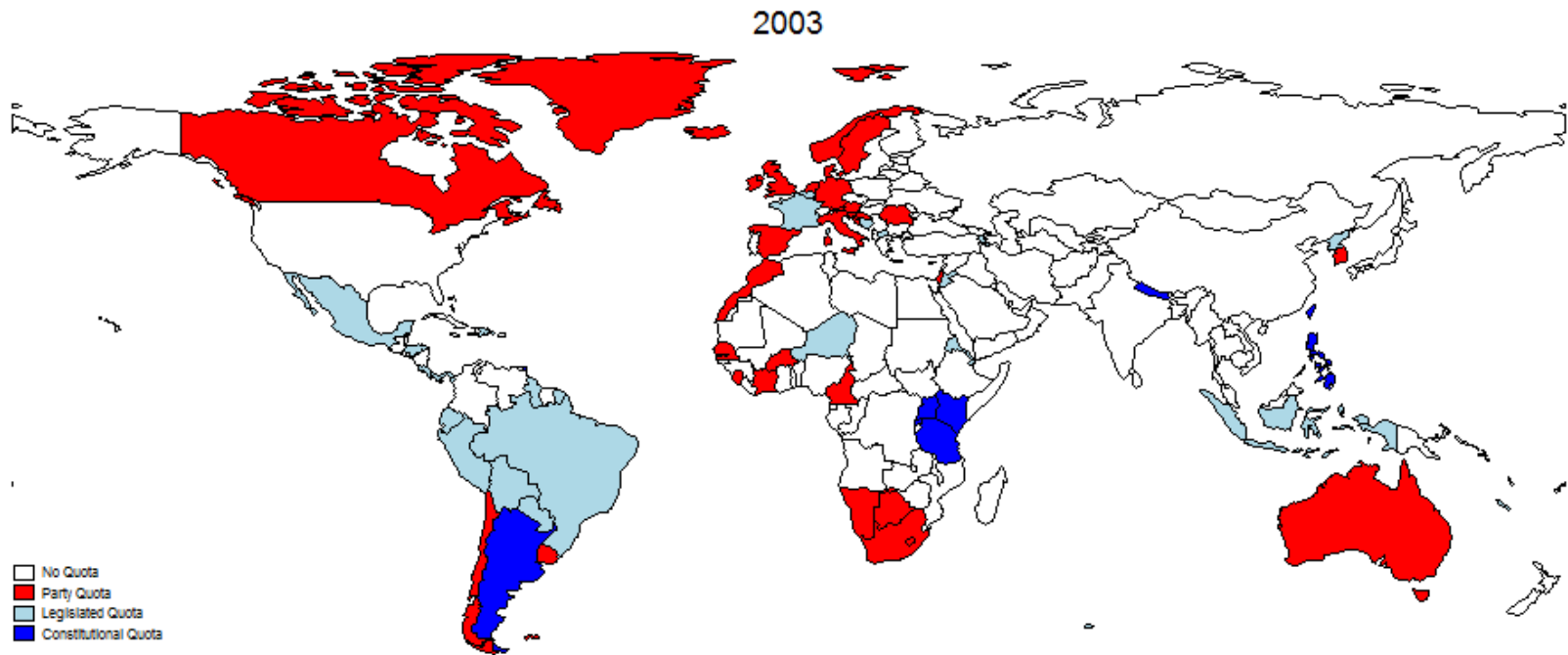

# Diffusion of Quotas 1975-2007

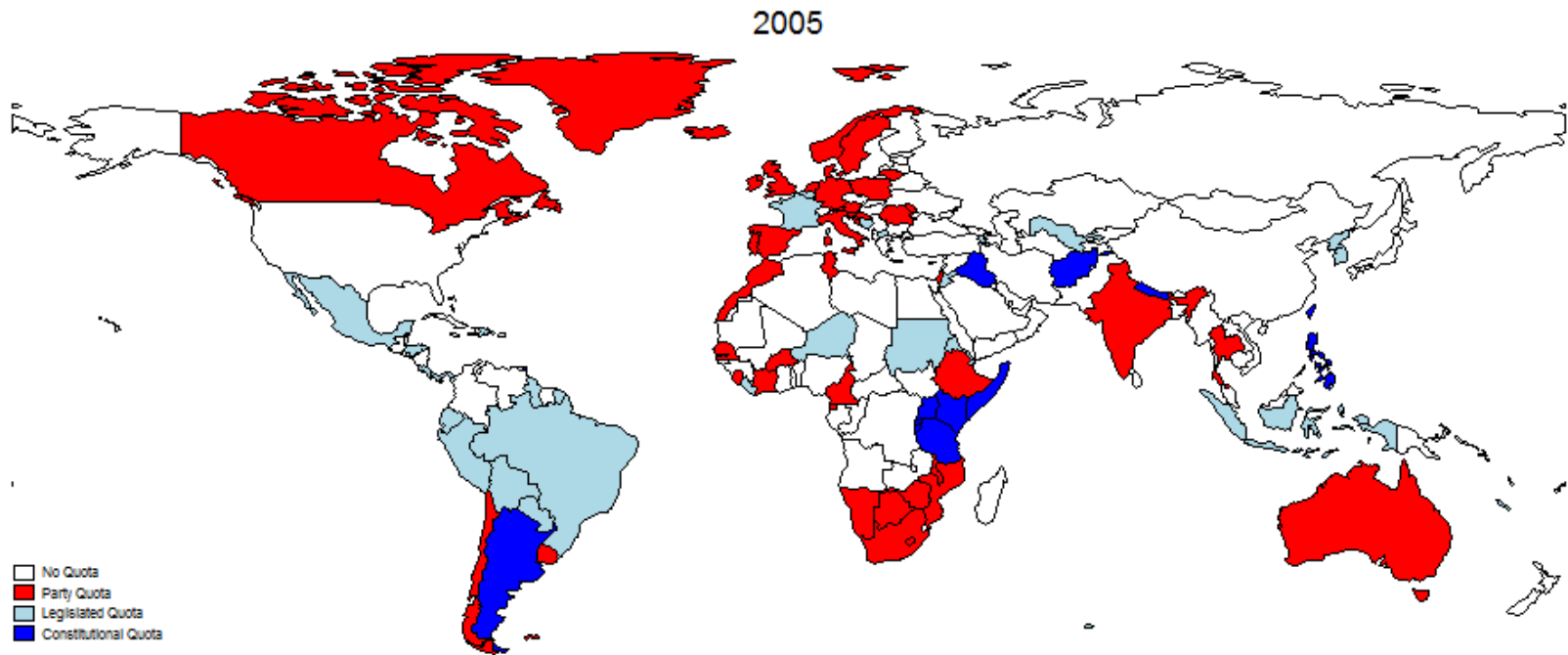



# Diffusion of Quotas 1975-2007

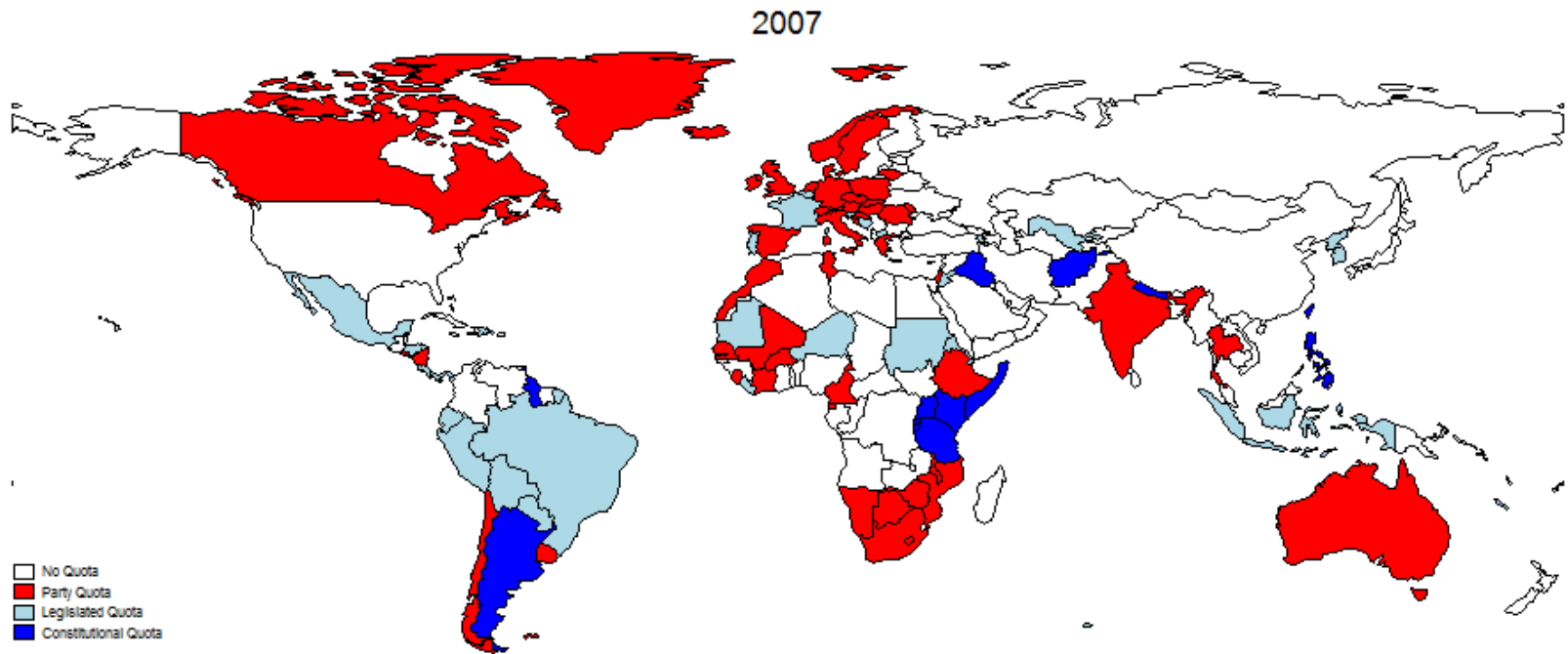

# Method 1: Event History Analysis

- A focus on timing and change
  - DV: The duration of time that units spend in a state before experiencing some event
  - Model the likelihood of Survival/failure given covariates

$$h(t) = Pr(T = t_i | T \geq t_i, X)$$

(SEE PDF FOR RESULTS)

# Method 2: Case Studies

- Level of Analysis: Sub-Region
  - Comparison of 2 African development communities, East African Community (EAC) and South African Development Community (SADC)

Quotas in the SADC (1) and EAC (2)

## Party Quotas

		1	0
Reserved Seats	1		Burundi (2), Kenya (2), Rwanda (2), Tanzania (1, 2), Uganda (2)
	0	Botswana (1), Mozambique (1), Namibia (1), South Africa (1), Zimbabwe (1)	DRC (1), Madagascar (1), Malawi (1), Mauritius (1), Seychelles (1), Swaziland (1), Zambia (1)

# Conclusions

- Bridging some gaps:
  - Relationship between diffusion mechanisms and internalization has been partially reconciled, but still under-theorized.